

Please note that the following installation/Cutout guide for Affinity should **NOT BE PRINTED** and used as a template. A template will be supplied with your item.

The dimensions below are meant as a guide only. Please double check your marking out against the unit before cutting into the furniture. All measurements have a $\pm 1\text{mm}$ tolerance to allow for errors while cutting.

If you require a physical template please contact our Technical Sales Team on +44 (0) 1709 829511 or e-mail sales@cmd-ltd.com, who will be able to arrange a physical copy of this template document to be sent out.



Affinity - Instruction Guide

Important: The dimensions below are meant as a guide only. Please double check your marking out against the unit before cutting into the furniture. All measurements have a $\pm 1\text{mm}$ tolerance to allow for errors while cutting.

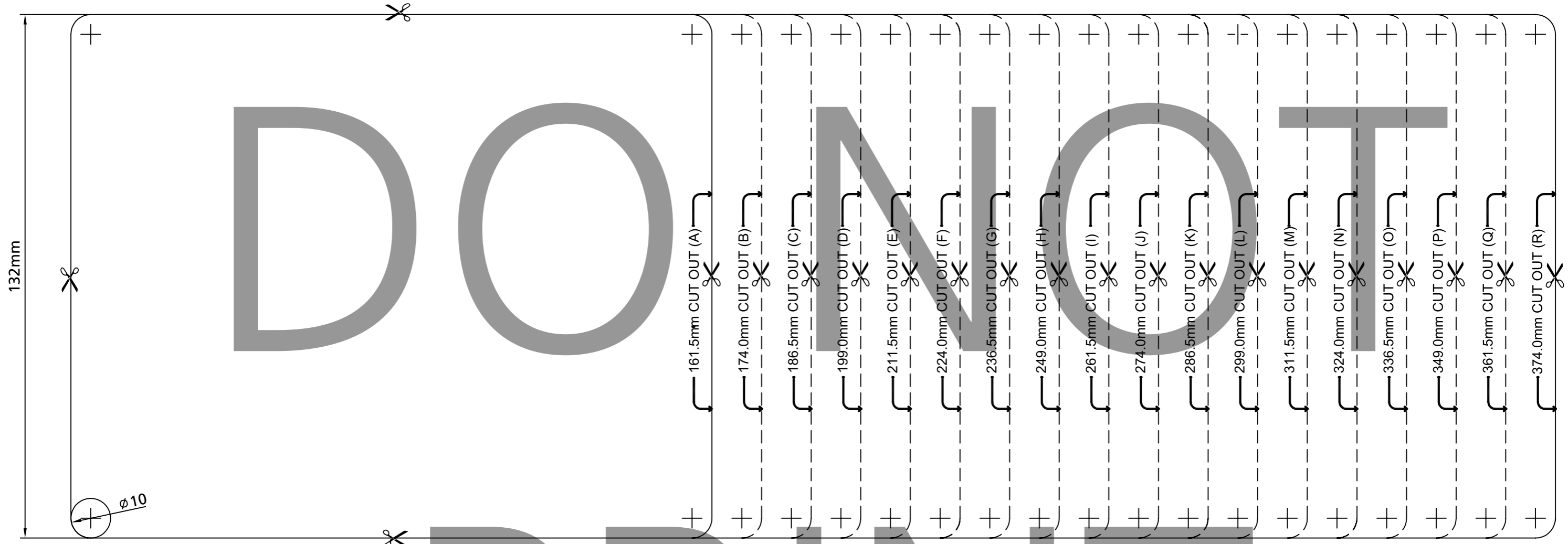

Part Number 132117. Issue 4 Date: February 2016

Instruction Guide

Installation is recommended by a competent person.

1. Pick a suitable position on the furniture ensuring there is sufficient clearance between the unit and the desk subframe.
2. Unpack the product, using the relevant template size (A to R marked on the product label fixed to the module) select the correct template, mark out and cut the aperture in the desk.
3. Without the two ratchet clamps being fitted, lower the unit into the aperture in the furniture.
4. Secure the unit with the ratchet clamps from beneath the furniture, pushing them up as far as they will go. The unit is now secure.

N.B. All and any works must be carried out in accordance with the appropriate Health & Safety regulations.

Operation

1. Lift the lid of the Affinity unit by taking hold of the edge adjacent to the soft flap. Move the unit up until an audible click is heard and the buttons pop out into place.
2. Insert plugs as required, taking care to support the unit.
3. The unit may be used in either the open or closed position to hide the plugs away, any surplus cable may then be pushed into the cable tray out of sight.
4. To close the unit push the buttons in on either side of the unit together and move the lid down to its closed position. **DO NOT** let it fall unsupported.
5. The cables should emerge from the unit through the soft flap.
6. To remove the plugs from the sockets repeat steps 1,2 & 3.

N.B. The unit contains no user serviceable parts. The retrospective installation of accessories must only be carried out by employees of CMD Ltd. Any failure to comply will invalidate any warranty.

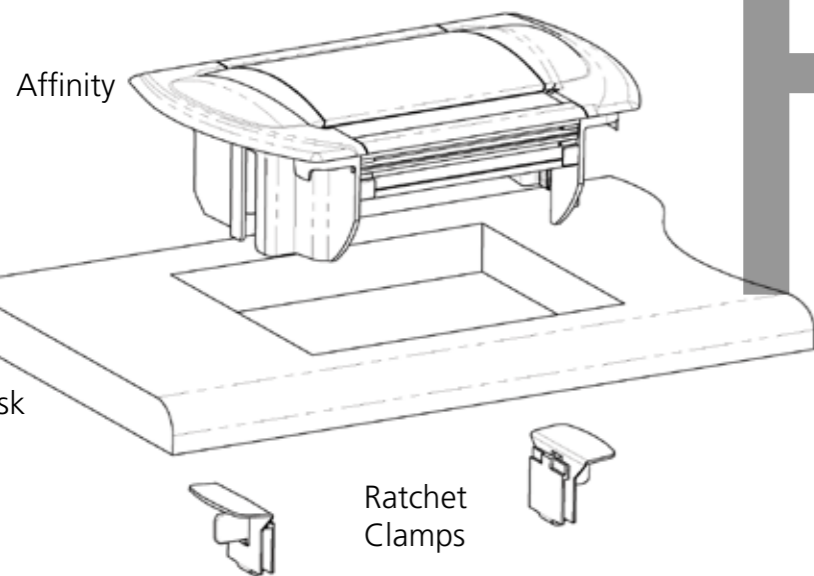

Ratchet
Clamps