

# Inca - Information and Instruction Sheet

Inca is a new module designed specifically for communal areas and meeting rooms. This stylish power and USB charging module is available in black, grey and white and has four faces that can be configured in a variety of ways to meet the power and data needs of any working environment.

## Main features

1. Choice of Black (fig. 02), Grey (fig. 03) or White (fig. 04) body and matching socket fascias. Other colour combinations available subject to minimum order quantities and lead times.
2. Inca has 4 usable faces offering a wide range of configurations for power and USB charging.
3. All UK sockets feature integral fuses with a choice of 3.15A or 5A fuses to comply with BS 6396.
4. All standard options are supplied with a 1m mains lead to male 3 pole connector.
5. Inca is available as a freestanding on desk module or as a grommet mount module.
6. The module is made of flame retardant ABS plastic body and is tested to comply BS 5733.



fig. 01

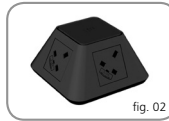

fig. 02

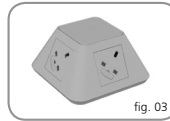

fig. 03

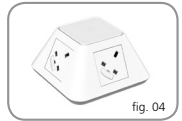

fig. 04

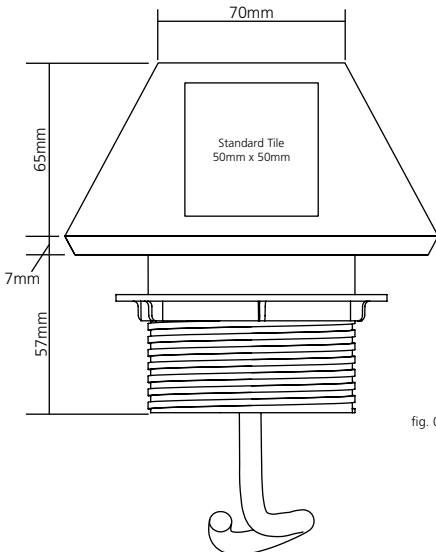

fig. 05

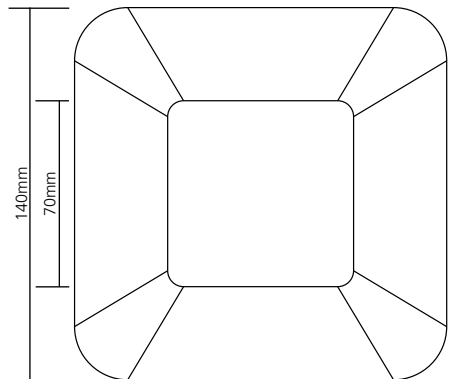

fig. 06



## Inca - Information and Instruction Sheet

### Fixing Instructions

1. The module has been designed to sit on the desktop but can also be fitted any precut 80mm grommet hole.
2. The grommet fixing version of PortHole IV is supplied with a hand tight fixing nut which must be removed before fitting (fig. 07).
3. The cable and threaded section of the module must be passed through the 80mm hole so that the hand tight fixing nut can be re-attached and tightened on the underside of the desk (fig. 08).
4. The module can then be connected to the power supply by a suitably qualified person.
5. Inca has been designed to fit desk thicknesses between 13mm and 50mm.

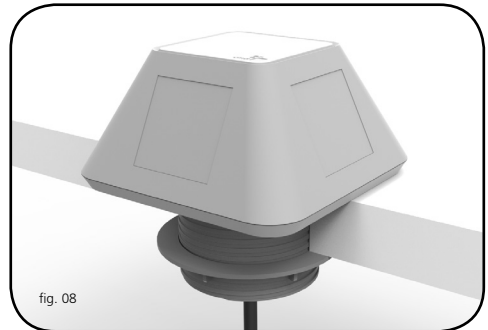
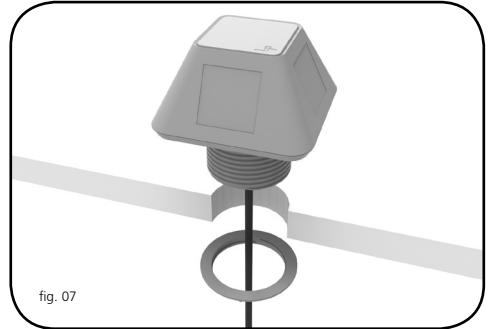

### Cleaning, Storage & Maintenance

Service Components	Available to order.
Cleaning & Maintenance	Dry cloth, no abrasives or solvents to be used on the module surface.
Handling & Storage	Do not drop or expose to moisture.

### Warning

- Do not use this product for any purpose other than which it was designed for.
- Do not over tighten the fixing nut.
- All electrical cables should be fitted by a qualified electrician.
- Do not attach power before fitting.
- Do not dismantle or remodel the power module.