



Inca - Power and Charging Module

Inca is a new module designed specifically for communal areas and meeting rooms. This stylish power and USB charging module is available in black, grey and white and has four faces that can be configured in a variety of ways to meet the power and data needs of any working environment.

Main features

1. Choice of Black (fig. 02), Grey (fig. 03) or White (fig. 04) body and matching socket fascias. Other colour combinations available subject to minimum order quantities and lead times.
2. Inca has 4 usable faces offering a wide range of configurations for power and USB charging.
3. All UK sockets feature integral fuses with a choice of 3.15A or 5A fuses to comply with BS 6396.
4. All standard options are supplied with a 1m mains lead to male 3 pole connector.
5. Inca is available as a freestanding on desk module or as a grommet mount module.
6. The module is made of flame retardant ABS plastic body and is tested to comply BS 5733.



fig. 01

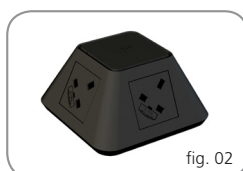

fig. 02

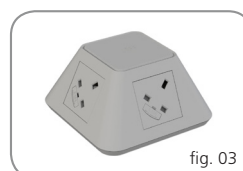

fig. 03

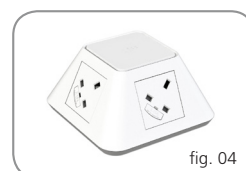

fig. 04

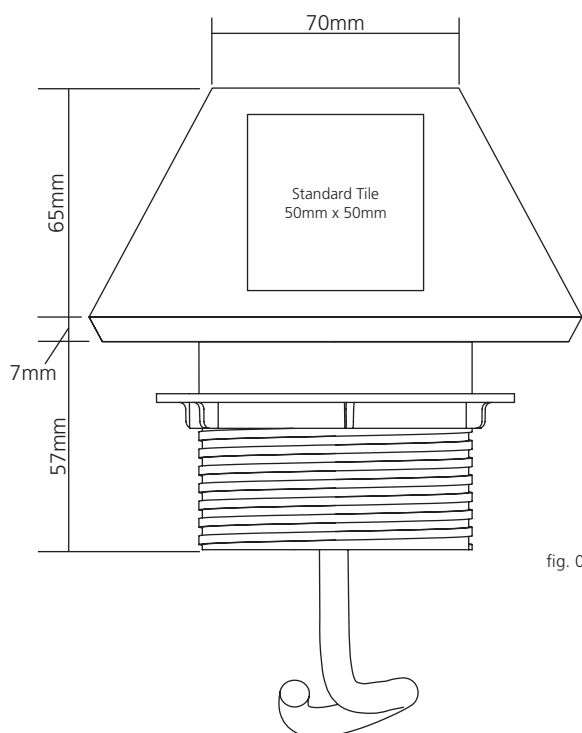

fig. 05

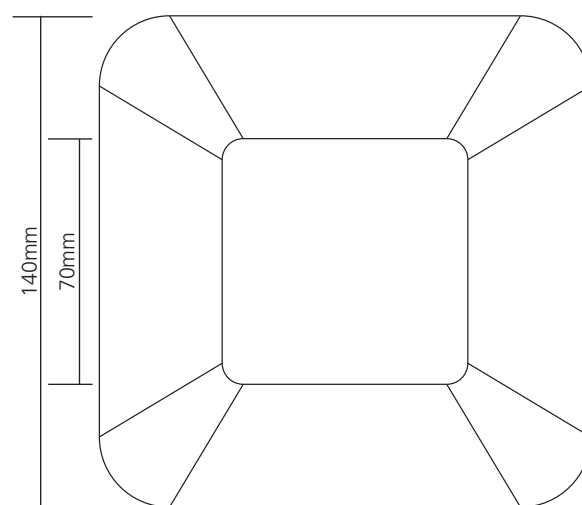

fig. 06

Warning

Do not use this product for any purpose other than which it was designed for.

Do not over tighten the fixing nut.

All electrical cables should be fitted by a qualified electrician.

Do not dismantle or remodel the power module.

Cleaning, Storage & Maintenance

Cleaning & Maintenance

Dry cloth, no abrasives or solvents to be used on the module surface.

Handling & Storage

Do not drop or expose to moisture.