



Arbour

Dynamic Monitor Arm



5 Year
Warranty



100%
Recyclable



INTRODUCTION

Meet Arbour - the modular dynamic, pole-based monitor arm system, designed to transform the way you work and play.

Designed to boost productivity across offices and commercial spaces, Arbour gives you the freedom to view more, do more - managing multiple applications, documents, and visual content with ease.

With its smooth height adjustment, support for up to four monitors (including curved monitors), and integrated cable management, it combines precision, practicality, and style.

KEY FEATURES

1. Flexible, modular dynamic, pole-based monitor arm system.
2. Single, double, triple and quad monitor setup from a single pole.
3. Supports flat and curved monitors up to 32" that weigh between 2kg and 9kg.
4. Quick release VESA for quick and easy monitor installation.
5. Gas strut and VESA head adjustment using a 5mm Allen key (not supplied).
6. Integrated cable management supports up to three $\varnothing 8\text{mm}$ cables per arm, to create safe and tidy installations.
7. Supplied with a choice of fixing options for desk thicknesses of 10mm to 80mm:
 - Tool free split-clamp fixing. (a single C-clamp is used with the 300mm pole and a double C-clamp is used with the 600mm pole).
 - Through desk ($\varnothing 12\text{mm}$) fixing with M10 Allen head bolt and spreader plate. Fitting requires a 6mm Allen key (not supplied).

DIMENSIONS

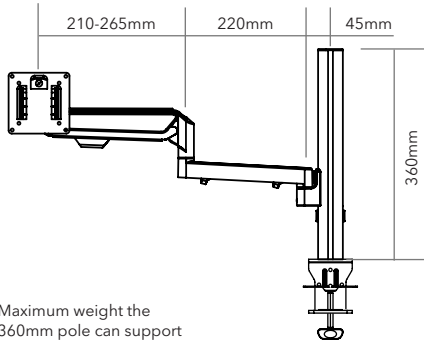

18kgs
Maximum weight the 360mm pole can support

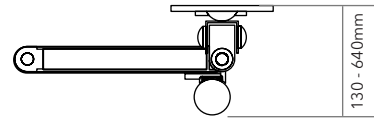

Dynamic Arm

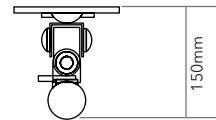

Fixed Head

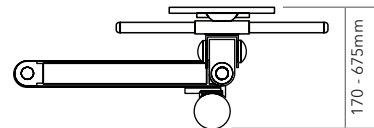

Dynamic Arm with Slider

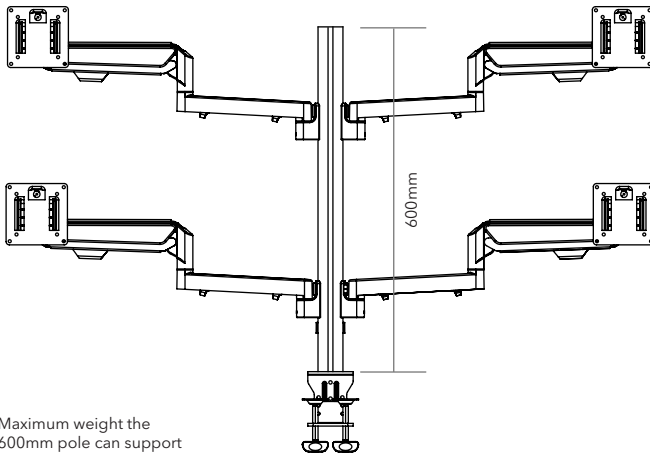

36kgs
Maximum weight the 600mm pole can support

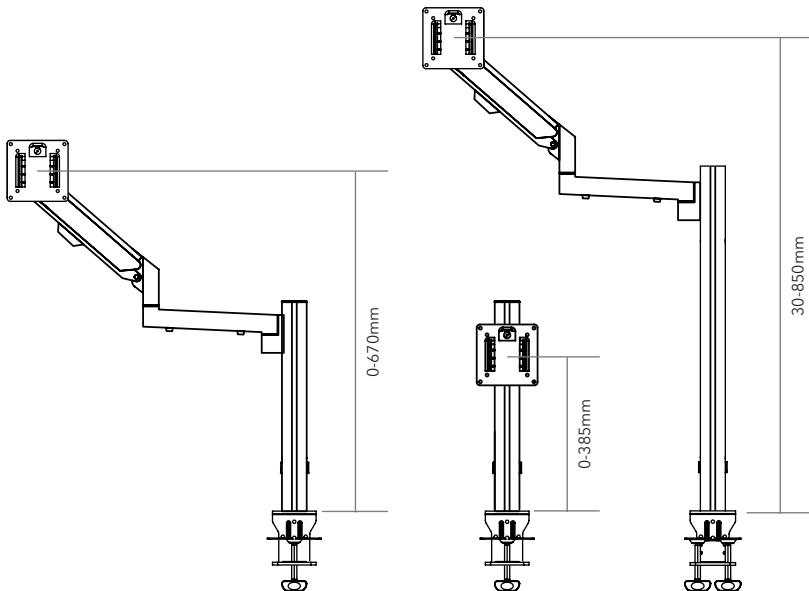

360mm Pole

600mm Pole

Single C-clamp used on 390mm pole

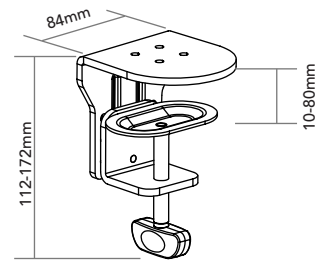

Double C-clamp used on 600mm pole

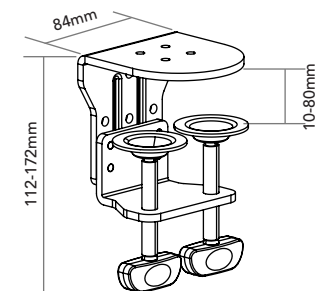

MOVEMENT

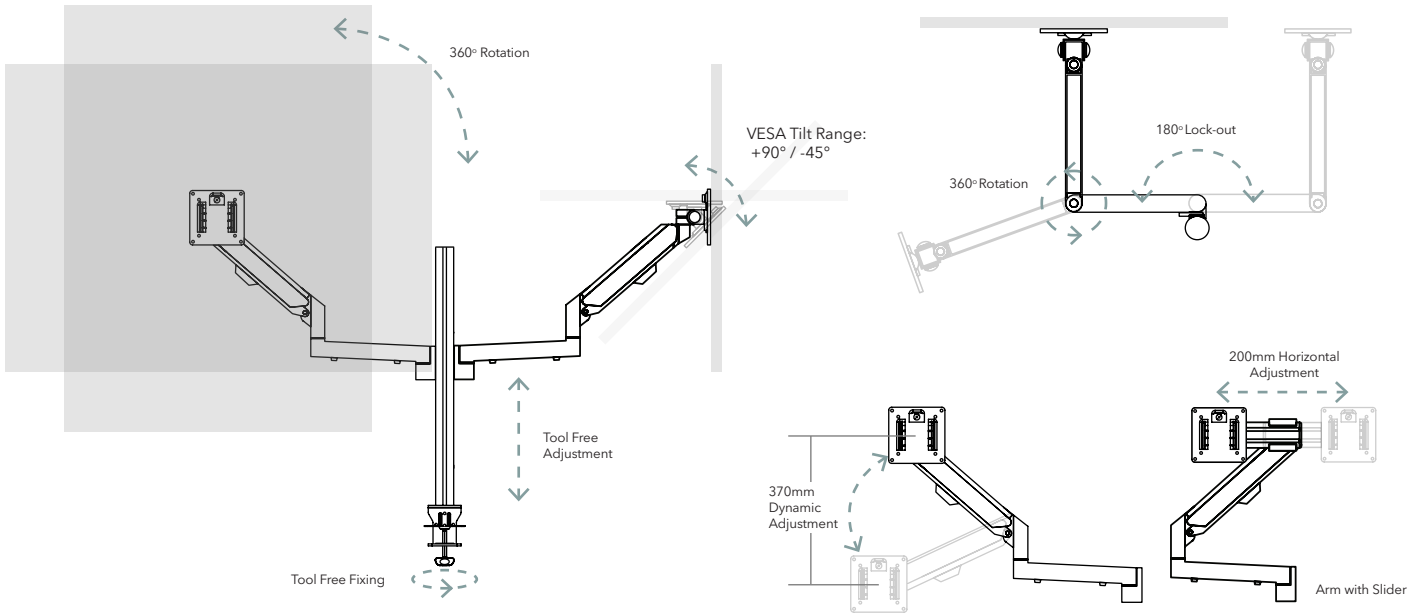

COMPATIBLE MONITOR SIZES

Maximum Width

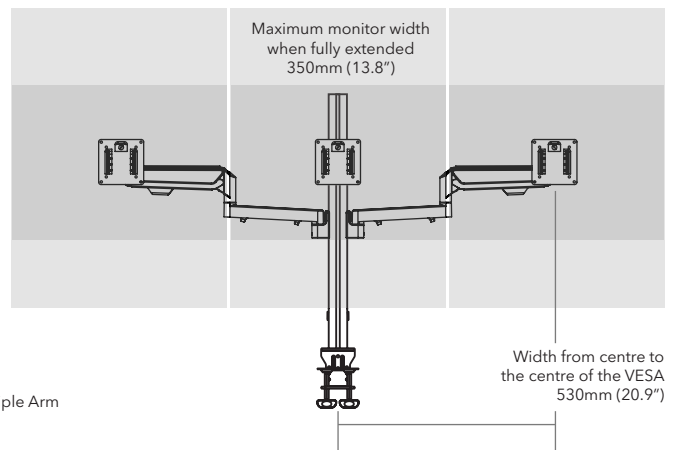
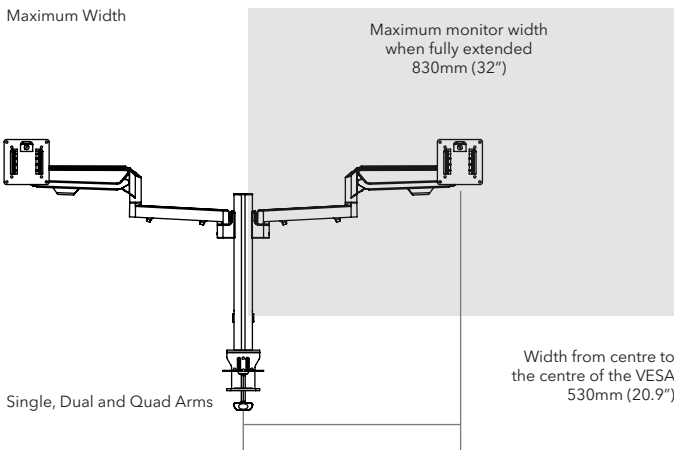

Maximum Height

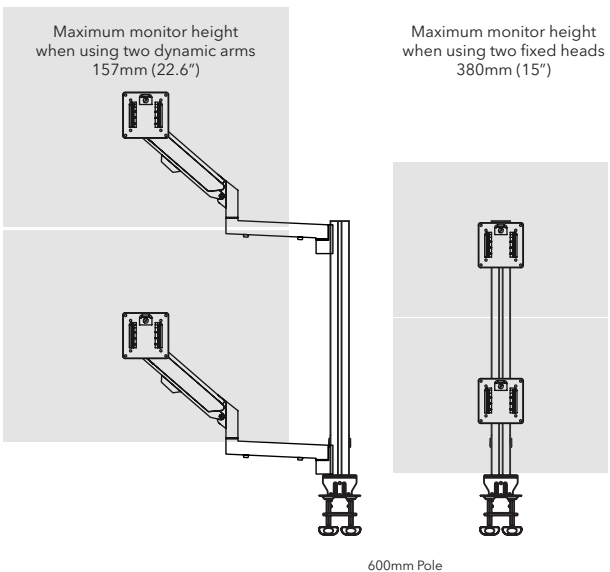

MONITOR SPECIFICATION

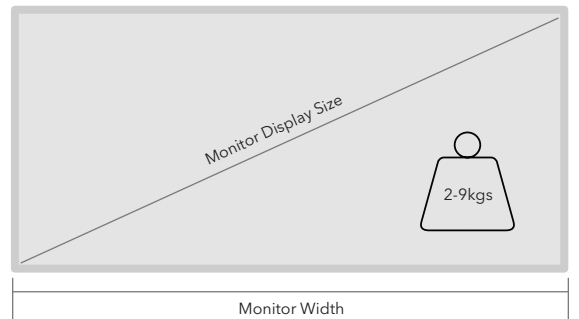

VESA Compatibility

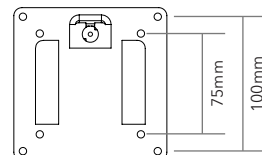

RANGE CONFIGURATIONS

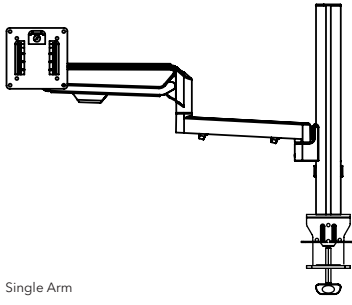

Single Arm

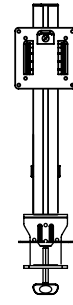

Single Fixed Head Arm

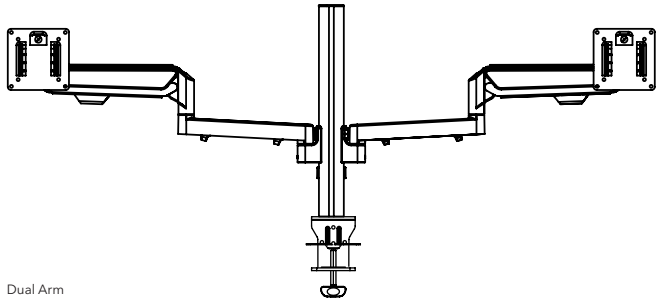

Dual Arm

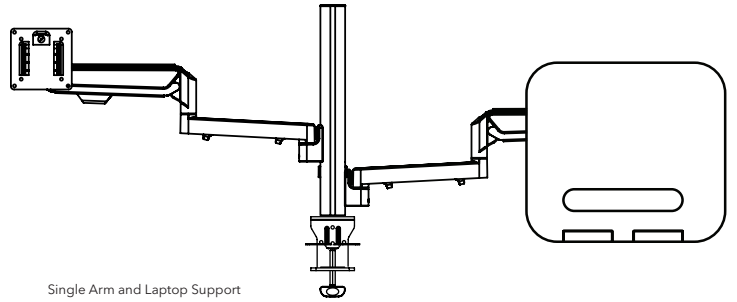

Single Arm and Laptop Support

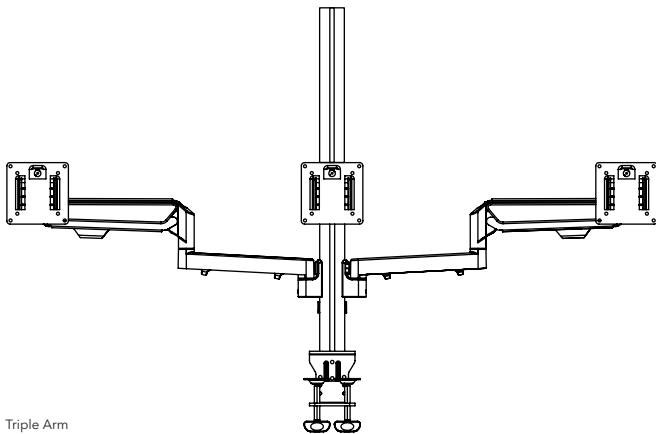

Triple Arm

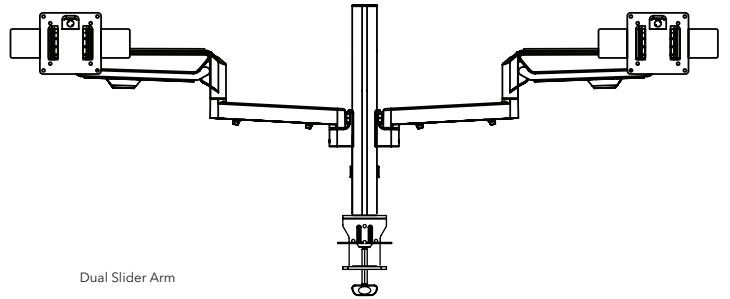

Dual Slider Arm

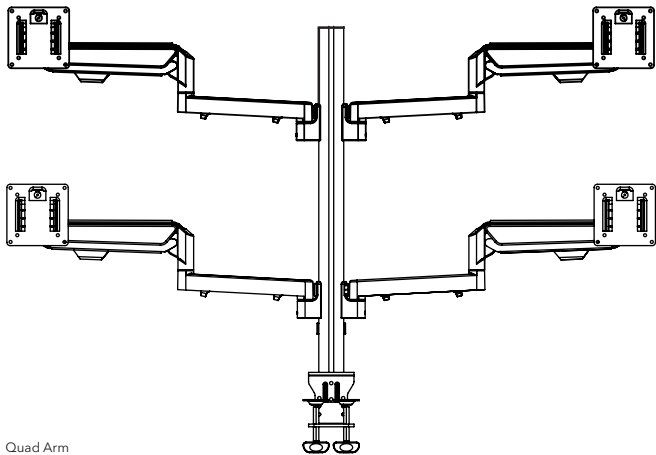

Quad Arm

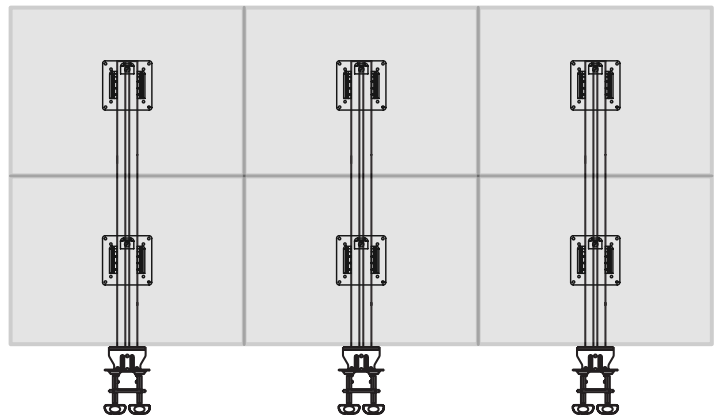

Bespoke Configurations

ORDERING

Arbour is a modular system that allows you to select from the product list below to build your perfect ergonomic workstation setup. Available in fine textured black and white, with C-clamp and through desk fixings included as standard.

Part Number	Description	Colour
68A001	Arbour 390mm Pole assembly with single C-clamp and bolt through mount fixing kit. Suitable for 1 or 2 Monitors. RAL 9005 - Fine textured.	●
68A002	Arbour 390mm Pole assembly with single C-clamp and bolt through mount fixing kit. Suitable for 1 or 2 Monitors. RAL 9003 - Fine textured.	○
68A003	Arbour 600mm Pole assembly with double C-clamp and bolt through mount fixing kit. Suitable for 3 or 4 Monitors. RAL 9005 - Fine textured.	●
68A004	Arbour 600mm Pole assembly with double C-clamp and bolt through mount fixing kit. Suitable for 3 or 4 Monitors. RAL 9003 - Fine textured.	○
68A005	Arbour Dynamic Arm (2kg to 9kg Monitor) - Quick Release VESA. RAL 9005 - Fine textured.	●
68A006	Arbour Dynamic Arm (2kg to 9kg Monitor) - Quick Release VESA. RAL 9003 - Fine textured.	○
68A007	Arbour Single Fixed Head - Quick Release VESA. RAL 9005 - Fine textured.	●
68A008	Arbour Single Fixed Head - Quick Release VESA. RAL 9003 - Fine textured.	○
68A009	Arbour Dynamic Arm With Slider (2kg to 9kg Monitor) - Quick Release VESA. RAL 9005 - Fine textured.	●
68A010	Arbour Dynamic Arm With Slider (2kg to 9kg Monitor) - Quick Release VESA. RAL 9003 - Fine textured.	○
67M020	Laptop Support. RAL 9005 - Fine textured.	●
67M021	Laptop Support. RAL 9003 - Fine textured.	○

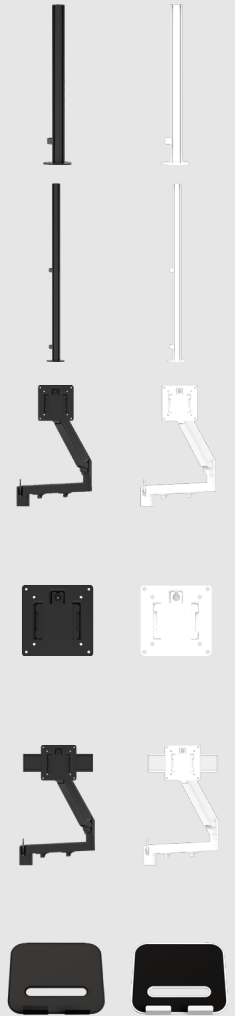

MATERIAL COMPOSITION

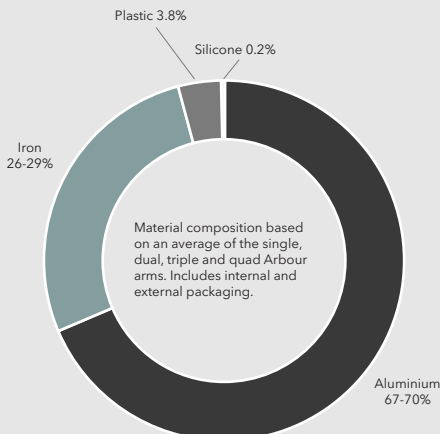

Website



User Guide
Single/Dual



User Guide
Triple/Quad